

# DIGIMACKS™ S1 Series

Differential Pressure Gauge / Switch / Transmitter

## Specification, Installation and Operating Manual



# FAUZ MECHANICS

227, Nirman Industrial Estate, Chincholi Bunder, Link Road,  
Malad West, Mumbai - 400 064.

Tel : +91 22 2876 3069 email: fauzmechanics@gmail.com

# CONTENT

1. Introduction :
  - 1.1 Model Configuration
  - 1.2 Specification
  - 1.3 Dimensional Drawing
2. Installation
  - 2.1 Mounting
  - 2.2 Pressure Connection
  - 2.3 Electrical Connection
  - 2.4 Wiring Diagram
3. Operation
  - 3.1 Display
  - 3.2 Front panel Description
  - 3.3 Key Function
4. Programing
  - 4.1 Default Parameter
  - 4.2 Program Flow
  - 4.3 Programming Mode
5. Other Feature
  - 5.1 Symbols
  - 5.2 Zeroing the S1
  - 5.3 Restoring Factory calibration
  - 5.4 Alarm Enable /Disable
  - 5.5 Instruction & Maintenance
  - 5.6 Default Parameter Of Other Ranges
  - 5.7 Warranty

## 1. Introduction:

**FAUZ MECHANICS** introduces S1 Series Pressure Instrument, which is a microcontroller based. 'DIGIMACKS™' that can be used to directly measure Pressure.

Differential and Absolute Pressure Gauge which support pressure up to 1000 mm wc.

The pressure output is displayed in selectable engineering unit of mm wc, and Pa. The S1 Series has been designed using the latest technology to provide reliable accuracy, using extremely stable Micro Electro Mechanical Sensor to give a standard full scale accuracy of 0.5%. The compact design makes the unit easy to install in the industry and serves as an excellent alternative to existing mechanical gauges. Pressure measurement can be displayed on a large, easy to read Seven segment display, which also indicates set points and range overflow condition.

### 1.1 Model Configuration:

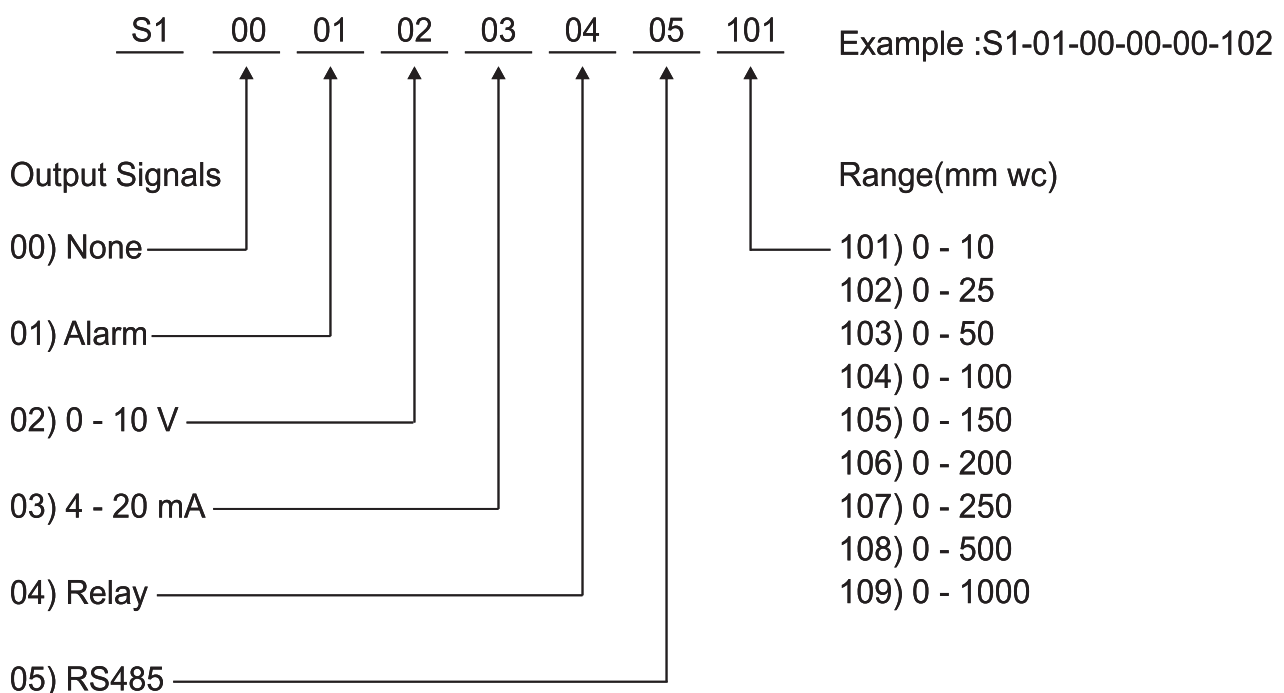

\* Customized Range available on request

## 1.2 Specification

Media compatibility	:	Air, non combustible, non corrosive gases
Supply Voltage	:	24 VDC
Accuracy	:	Ranges: $\leq 0 - 10$ mm Wc. $\pm 1.0\%$ of F. S, Ranges: $\geq 0 - 25$ mm Wc $\pm 0.5\%$ of F. S.
Display	:	4 Digit Seven Segment
Output Signals	:	Audio - Visual Low & High Pressure Alarm
Optional Output	:	4-20 mA/ 0 - 10 V/ Relay /RS485
Response Time	:	100 - 3000 m Sec (Selectable via Menu)
Operating Temperature	:	10° to 60°C
Storage Temperature	:	-30° to +100° C
Over Pressure	:	Ranges: $\leq 50$ mm Wc : 9 PSI, 100 to 1000 mm Wc :19 PSI
Switch	:	Digital push button.
Front Cover	:	SS 304
Housing Material	:	Glass filled nylon
Electrical Connections	:	Screw terminals
Process Connection	:	Push on connection for 3/16" ID tubing
Weight	:	230 Gram.
Dimensions	:	114 Dia. X 30 mm depth

## 1.3 Dimensional Drawing

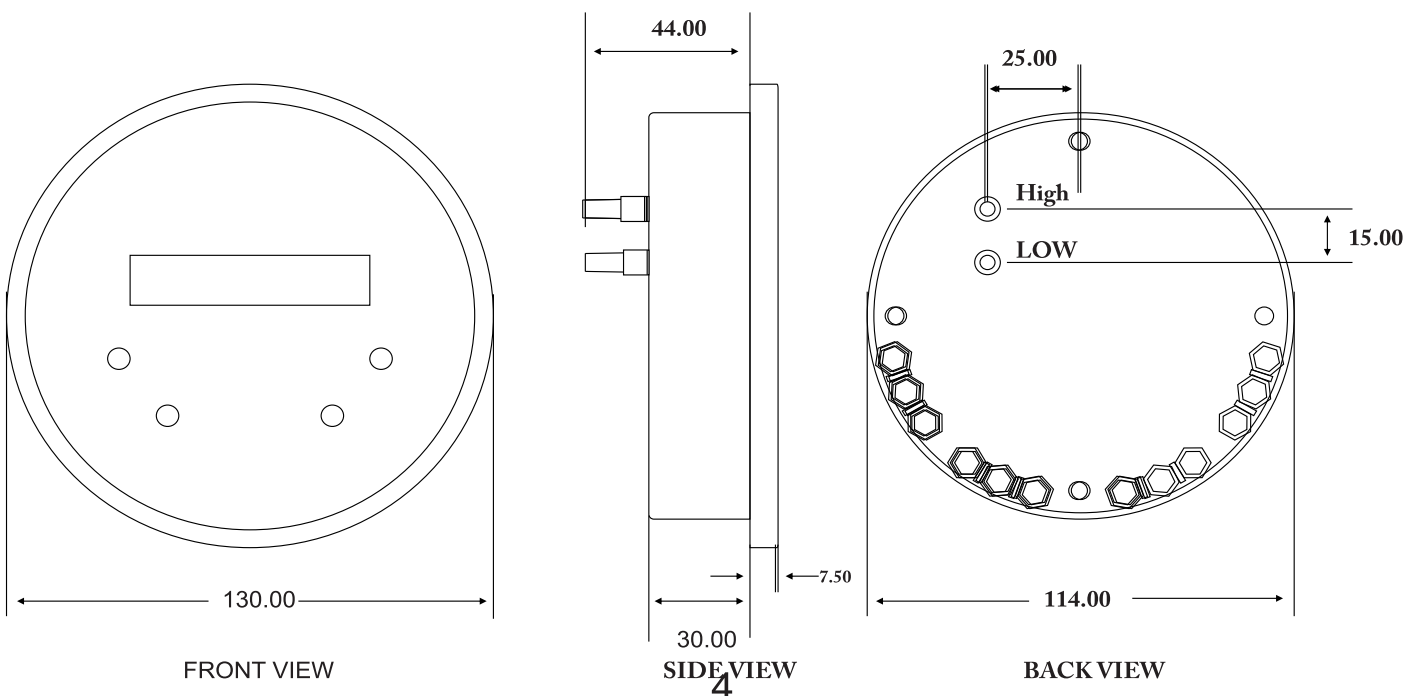

## 2. Installation

### 2.1 Mounting

The 'DIGIMACKS™S1 should be mounted by making cutout of 114.00 mm diameter in the panel. Insert the Gauge through the hole and secure it to the panel with the provided mounting tabs and screws. DIGIMACKS™S1 Series have been designed to fit in industry standard cutout of 114.00 mm

### 2.2 Pressure Connection:

For installation convenience inbuilt two pressure ports are provided at back side of pressure gauge.

**Positive Pressure :** Connect tubing to HIGH PRESSURE port and vent LOW PRESSURE port to atmosphere.

**Negative (Vacuum) Pressure -** Connect tubing to LOW PRESSURE port and vent HIGH PRESSURE port to atmosphere.

**Differential Pressure -** Connect tubing from the higher source to HIGH PRESSURE port and from the lower source to LOW PRESSURE port.

### 2.3 Electrical Connection:

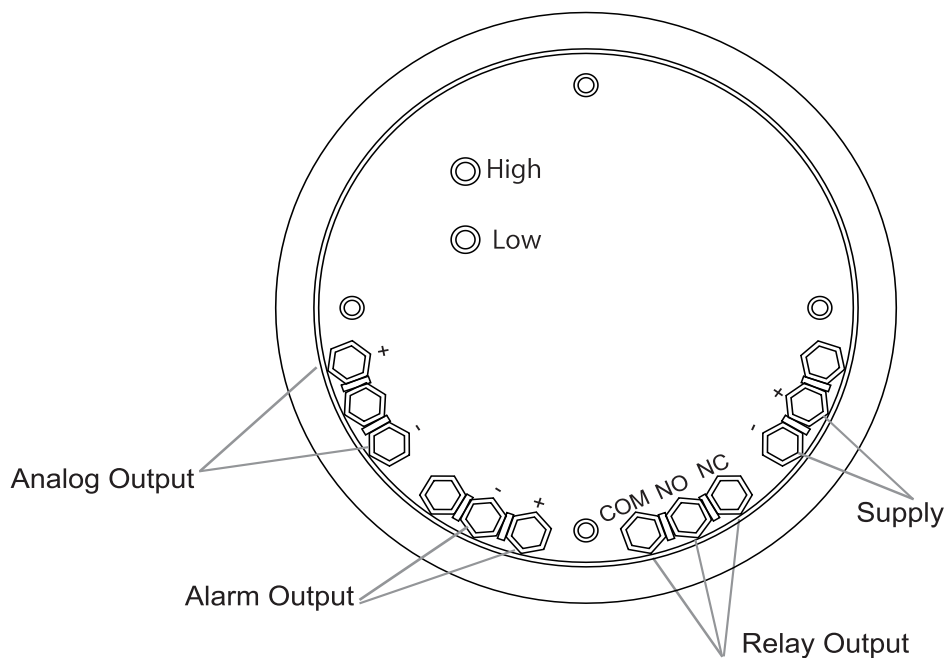

**Note :**

*The Instrument can be powered 24 VDC (at different screw terminal shown in the above figure.)*

*For low and high pressure alarm connect wire as shown in the figure.*

*For Analog Output connect wire as shown in the figure. (Page 6)*

## 2.4 Wiring Diagram

To make the connection, the transmitter must not be energised. Attach wiring from your equipment according to the following terminal connections and wiring diagrams depending on your circumstances.

### WIRING DIAGRAM 1

Input Supply : 24 VDC Output Signal : 0 -10 Volt (3 Wire)

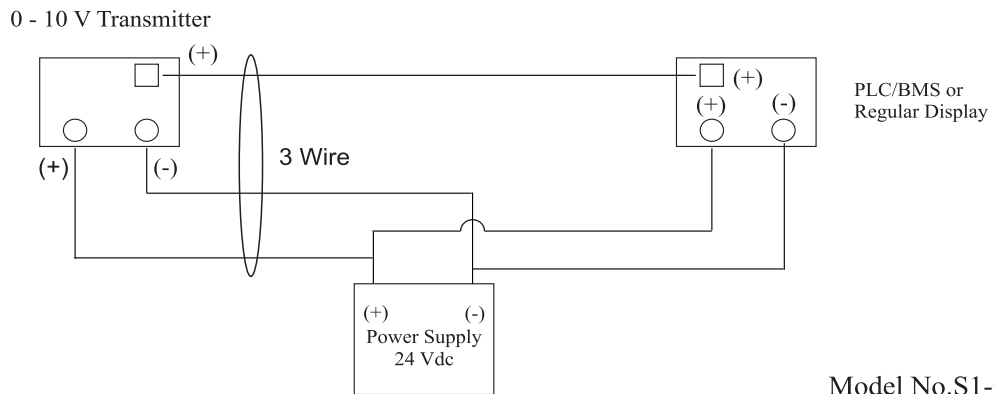

### WIRING DIAGRAM 2

Input Supply : 24 VDC Output Signal : 4 -20 mA (3 Wire)

To make a 3 wire connection, before powering up transmitter, please connect output ground to the input ground, see drawing below.

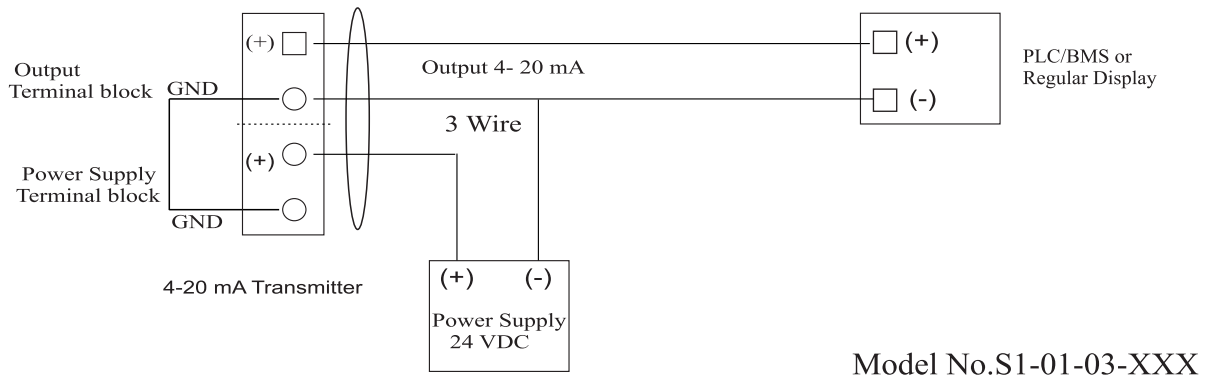

### WIRING DIAGRAM 3

Input Supply : 24 VDC Output Signal : 0 -10 Volt or 4-20 mA (4 Wire)

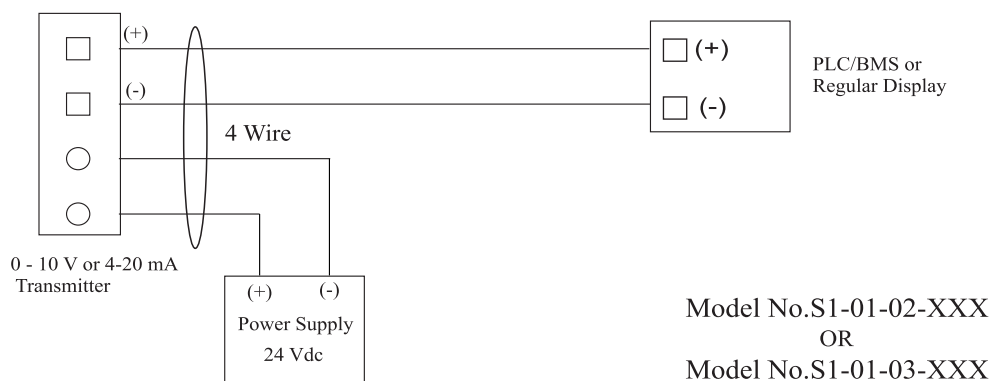

### 3.1 Display:

The **DIGIMACKS™** S1 series were designed to give the user maximum feedback and flexibility. Negative pressure will be indicated by the negative sign before the numerical indication. The 4 digit LED displays the numerical pressure reading and will show various parameter and set points. The Green, Yellow and Red LED Shows the Alarm condition. Four easy to operate keys help to access and modify various parameter.

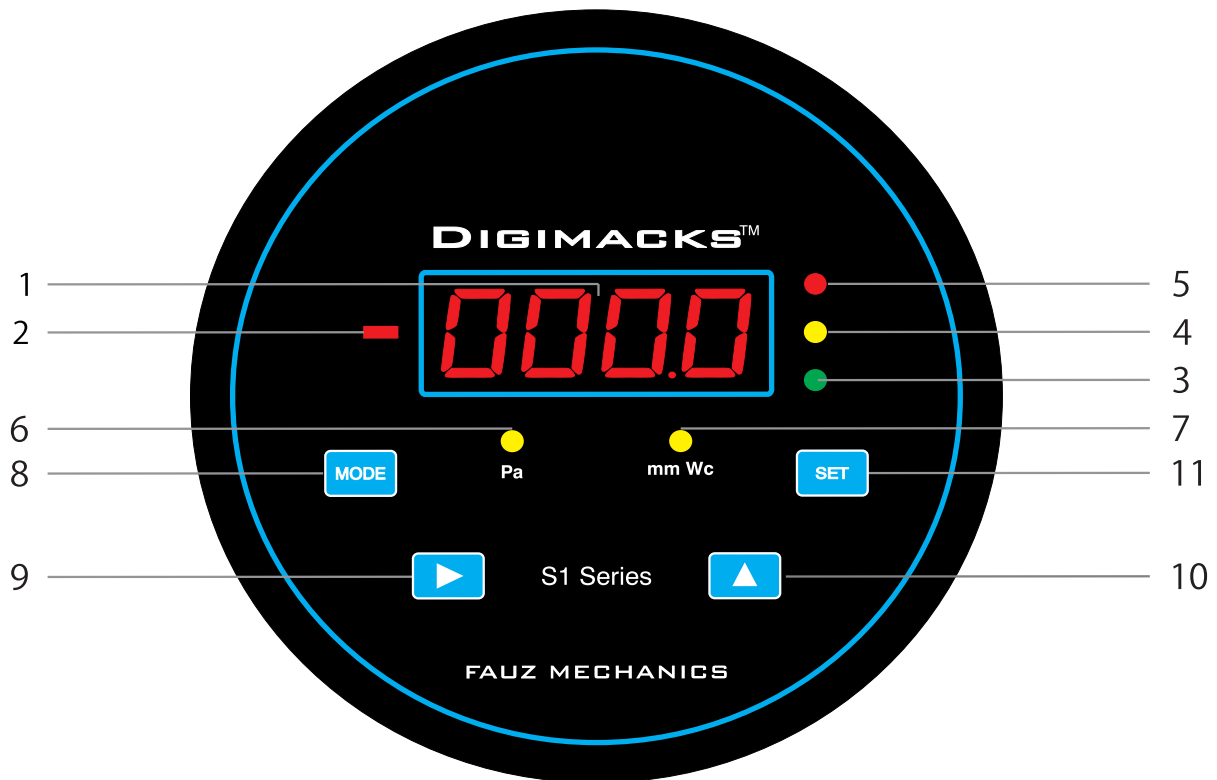

### 3.2 Front Panel Description:

Sr No	DISPLAY	DESCRIPTION
1	0000	LED Pressure indication
2	Red LED	Negative Indication
3	Green LED	Will Glow When Pressure in Normal Condition
4	Yellow LED	Will Glow When Pressure delay time Condition
5	Red LED	Will Glow When Pressure in faulty Condition
6	Yellow LED	Will Glow When Pressure unit Selected in Pa
7	Yellow LED	Will Glow When Pressure unit Selected in mm Wc

### 3.3 Key Function:

Sr No.	8	9	10	11
Display				
Description	Mode Key	Shift Key	Increment Key	Set Key
Normal Mode	Press to access the Programming Menu	Press to save Zero	_____	_____
Programing Menu	Press to exit from programing menu	Down key to select parameter	Up key to select parameter	_____
Editing Menu	Press to exit from editing menu	Press to move cursor to select digit	Press to Increase selected Digit	Press to accept the entered value
Keypad Locked (Mode)	Press to Enable / Disable Alarm	_____	_____	_____

### 4.1 Defalut Parameters:

Range: 0 - 10 mm Wc (For Other Range Refer Page 11)





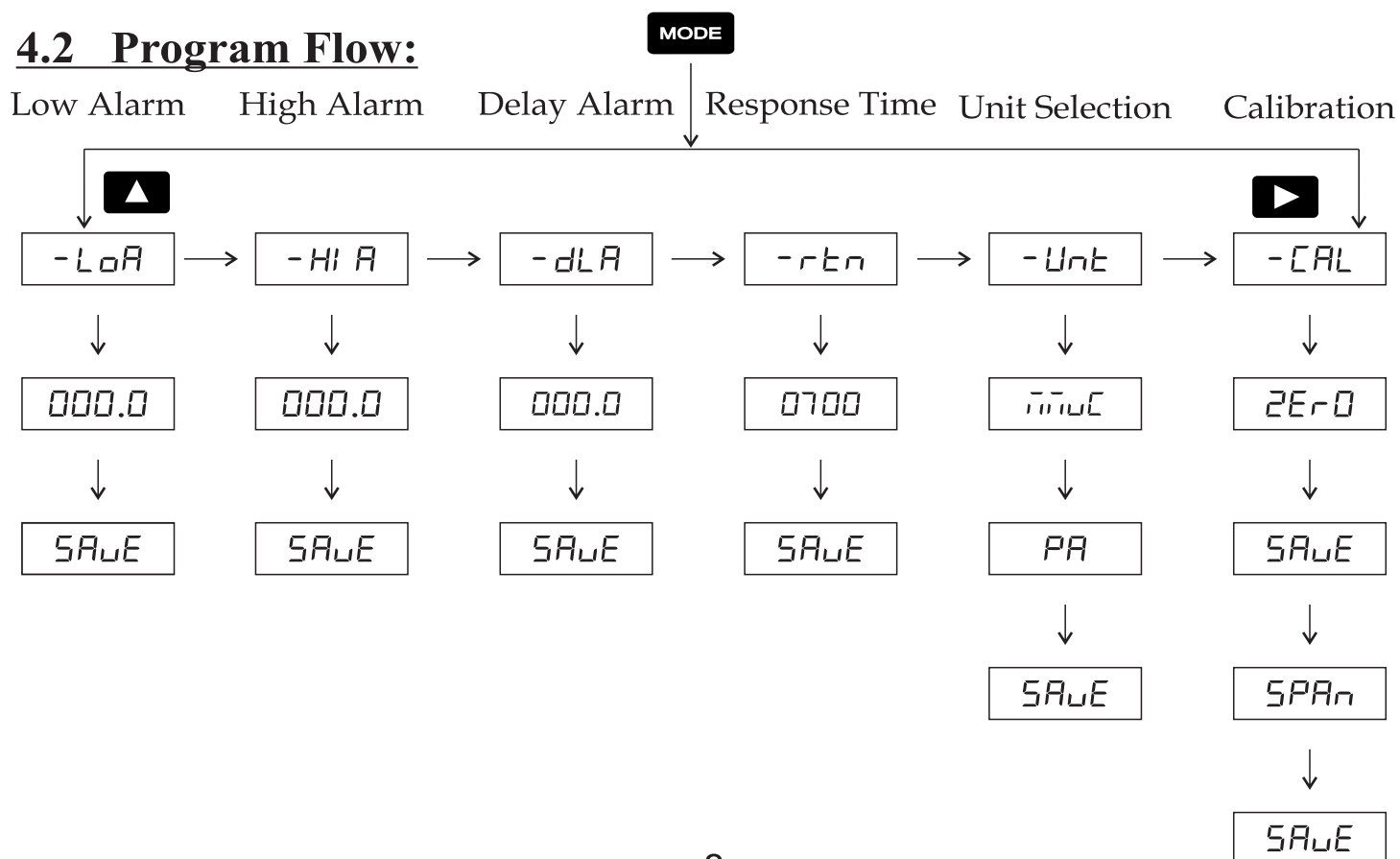













Sr. No.	Parameter	Default Value	Programmable Range	Unit
1.	Low Alarm	0.5	- 10.0 to 10.0	mm Wc
2.	High Alarm	5.0	- 10.0 to 10.0	mm Wc
3.	Delay Alarm	001	0 - 999	Sec
4.	Response Time	700	1 - 3000	mil. Sec
5.	Unit Selection	mm Wc	mmWc / Pa	Pressure
6.	Range	0 - 10	_____	mm Wc

### 4.2 Program Flow:





## 4.3 Programing Mode:

Sr. No.	Description	Key to Press	Display	Action	Note
1	To Unlock keypad	Simultaneously press  &  key	<i>ULoc</i>	Keypad Unlocked	
2	To enter in to programming mode		<i>-LoA</i>	Low Alarm	Press Set To Enter
3	To edit & save		<i>007.0</i>	Rightmost Digit will start blinking. Use  key for selection and  for change digit	Press SET to Save
4	To enter in to High Alarm		<i>-Hi A</i>	High Alarm	Press Set To Enter
5	To edit & save		<i>017.0</i>	Using Combination of  /  edit the value	Press Set To Save
6	To enter in to Delay Alarm		<i>-dLA</i>	Delay Alarm	Press Set To Enter
7	To edit & save		<i>0001</i>	Using Combination of  /  edit the value	Press Set To Save
8	To enter in to Response Time		<i>-rtn</i>	Response Time	Press Set To Enter
9	To edit & save		<i>0700</i>	Using Combination of  /  edit the value	Press Set To Save
10	To Select Pressure Unit		<i>-Unt</i>	Unit	Press Set To Enter
11	To edit & save		<i>101.0</i>	Using Combination of  /  edit the value	Press Set To Save
12	To Enter into Calibration Mode		<i>-CAL</i>	Calibration	Press SET To Enter
13	Zero	Disconnect both pressure connections so that they are open to atmospheric Pressure.	<i>ZEro</i>	Press SET to Save	The display will advanced to <i>SPAN</i> menu
14	Span	To Span the gauge, apply the full scale pressure to the high pressure port and let the pressure stabilized.	<i>SPAN</i>	Press and hold the SET key until <i>SPAN</i> is displayed	Calibration done Press Mode to exit from Calibration menu

## 5.1 Symbols:

Sr. No.	Symbols	Description
1	<i>d 15</i>	Alarm Disabled
2	<i>En</i>	Alarm Enabled
3	<i>PaFL</i>	Positive Pressure Overflow
4	<i>naFL</i>	Negative Pressure Overflow
5	<i>1 nUL</i>	Entered Invalid Value

## 5.2 Zeroing the S1:

To re-zero the **DIGIMACKS**<sup>™</sup> Pressure Gauge, disconnect both pressure connections so they are open to atmospheric pressure and press and hold the  for about 3- 4 seconds. This will reset Zero point of Gauge.

## 5.3 Restoring Factory Calibration

The factory defaults can be easily restored by simultaneously press both the  and **SET** key and holding them for approximately 3-4 seconds. Once you have press both keys “*F C r*” is

## 5.4 Alarm Enable and Disable

For using this feature **KEYPAD** must be in **LOCK** mode.

**Alarm Enable:** This can be done by pressing  key until “*En*” is displayed.

**Alarm Disable:** This can be done by pressing  key until “*d 15*” is displayed.

## 5.5 Instructions and Maintenance:

Occasionally disconnect pressure lines to vent both sides of gauge to atmosphere and re-zero.

When making tubing connection DO NOT apply torque to tube fitting that can cause fitting to turn of twist with respect to plastic enclosure.

Doing so will damage the product and void the warranty. The Applied pressure should not exceed the specified upper limit of the pressure gauge.

The electrical connection must be firm and proper. Instrument should not be subjected to excessive temperature.

In case of malfunctioning of the instrument, please contact the manufacturer.

## **5.6 Defalut Parameters of Different Range:**

### **5.6.1: Range: 0 - 25 mm Wc**

Sr. No.	Parameter	Default Value	Programmable Range	Unit
1.	Low Alarm	7.0	- 25.0 to 25.0	mm Wc
2.	High Alarm	17.0	- 25.0 to 25.0	mm Wc
3.	Delay Alarm	001	0 - 999	Sec
4.	Response Time	700	1 - 3000	mSec
5.	Unit Selection	mm Wc	mmWc/Pa	Pressure
6.	Range	0 - 25	—	mm Wc

### **5.6.2: Range: 0 - 50 mm Wc**

Sr. No.	Parameter	Default Value	Programmable Range	Unit
1.	Low Alarm	7.0	- 50.0 to 50.0	mm Wc
2.	High Alarm	20.0	- 50.0 to 50.0	mm Wc
3.	Delay Alarm	001	0 - 999	Sec
4.	Response Time	700	1 - 3000	mSec
5.	Unit Selection	mm Wc	mmWc/Pa	Pressure
6.	Range	0 - 50	—	mm Wc

### **5.6.3: Range: 0 - 100 mm Wc**

Sr. No.	Parameter	Default Value	Programmable Range	Unit
1.	Low Alarm	20.0	- 100.0 to 100.0	mm Wc
2.	High Alarm	70.0	- 100.0 to 100.0	mm Wc
3.	Delay Alarm	001	0 - 999	Sec
4.	Response Time	700	1 - 3000	mSec
5.	Unit Selection	mm Wc	mmWc/Pa	Pressure
6.	Range	0 - 100	—	mm Wc

### **5.6.4 : Range: 0 - 250 mm Wc**

Sr. No.	Parameter	Default Value	Programmable Range	Unit
1.	Low Alarm	80.0	- 250.0 to 250.0	mm Wc
2.	High Alarm	200.0	- 250.0 to 250.0	mm Wc
3.	Delay Alarm	001	0 - 999	Sec
4.	Response Time	700	1 - 3000	mSec
5.	Unit Selection	mm Wc	mmWc/Pa	Pressure
6.	Range	0 - 250	—	mm Wc

## **5.7 Warranty**

**FAUZ MECHANICS** warrants its products to be free from defects in materials and workmanship for a period of 1 years from the date of shipment, subject to the following terms and conditions: Without charge, we will repair, replace the product found to be defective in materials or workmanship within the warranty period; provided that:

1. The product has not been subjected to abuse, neglect, accident, incorrect wiring not our own, improper installation or servicing.
2. The product has not been repaired or altered by anyone.
3. The product is returned to our factory, transportation prepaid before expiration of the warranty.